

CRS03

Angular Rate Sensor

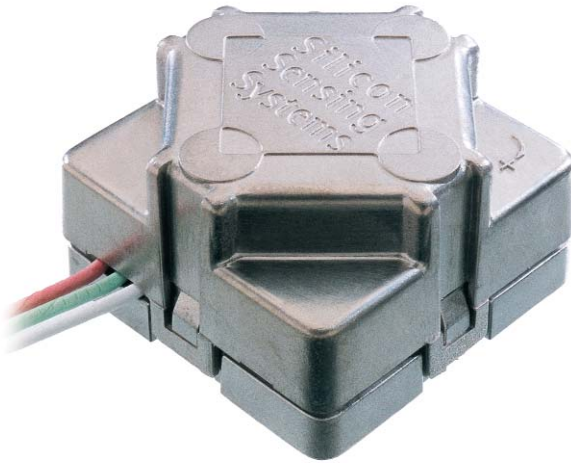

A robust and affordable mass-produced gyroscope for automotive and commercial customers.

Angular rate sensors are used wherever rate of turn sensing is required without a fixed point of reference. The sensor will output a DC voltage proportional to the rate of turn and input voltage.

High performance motion sensing even under severe shock and vibration.

Whatever your application, the unique silicon ring technology, coupled with closed loop electronics, gives advanced and stable performance over time and temperature, overcoming the mount sensitivity problems experienced with simple beam or tuning fork based sensors.

Key Features

- Three model types available
- Excellent performance over temperature
- Repeatable drift characteristic
- High shock and vibration operation
- High reliability
- Metalised housing



CRS03

Angular Rate Sensor

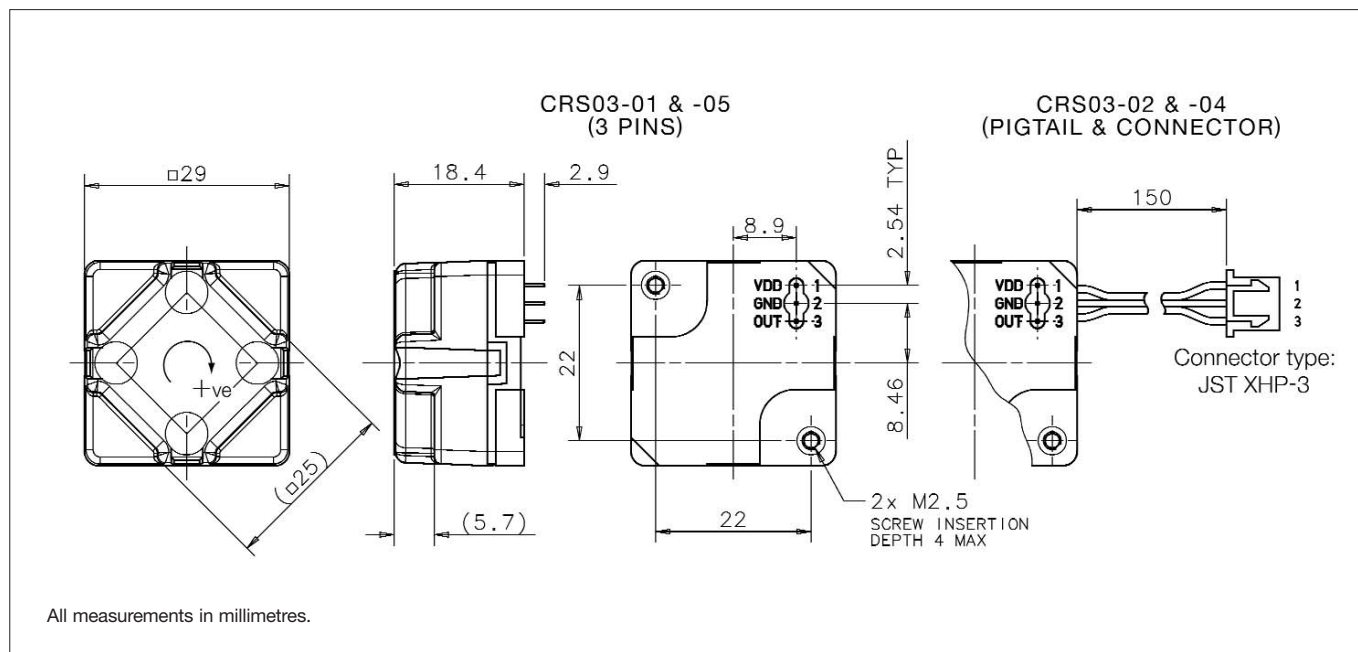

Specification

Specification (Typical Data)	-01S & -02S	-04S	-05S
Angular Rate Range	±100°/s	±200°/s	±80°/s
Output	Analogue voltage (ratiometric)		
Scale Factor			
Nominal	20mV/°/s	10mV/°/s	25mV/°/s
Variation over temperature range	< ±5%		
Nonlinearity	< ±0.5% of full scale		
Bias			
Setting tolerance	< ±3°/s	< ±6°/s	< ±4°/s
Variation over temperature range	< ±3°/s	< ±6°/s	< ±4°/s
Ratiometric error	< ±1°/s		
Drift vs. time	< ±0.55°/s in any 30s period (after start-up time)		
g sensitivity	< ±0.1°/s/g on any axis		
Bandwidth	10Hz (-3dB)		
Quiescent Noise	< 1mV rms		
Environment			
Temperature	-40°C to +85°C		
Linear acceleration	< 100g		
Shock	200g (1ms, ½ sine)		
Vibration	2g rms (20Hz to 2kHz, random)		
Cross-axis sensitivity	< 5%		
Mass	< 18 gram		
Electrical			
Supply voltage	+4.75V to +5.25V		
Supply current	< 35mA (steady state)		
Noise and ripple	< 15mV rms (DC to 100Hz)		
Start-up time	< 0.2s		
RoHS Compliance	Yes (R & S suffix)		

Pin Connections

1	+5V
2	0V
3	Rate Output