

Undisclosed tolerances - 0.5 IT14

OUTLINE DRAWING

MAIN PARAMETERS

◆ Rate range	230 deg/s
Scale Factor (SF)	6 mV/deg/s
Frequency range	0... 1 kHz
Angle random walk	0.05 deg /√h
Bias stability	20 deg / h (RMS)
SF variation (steady state)	0.1 % (RMS)
Readiness time	0.02 s

ENVIRONMENT

Temperature operating	-30°C ... +70°C
endurance	-55°C... +85°C
Vibration (operating)	2 g (RMS), 20Hz... 500Hz
Vibration (endurance)	2 g (RMS), 20Hz... 500Hz
Shocks (endurance)	40 g, 1 ms
Acceleration (operating)	5 g
Acceleration (endurance)	20 g, 5 s

RELIABILITY

MTBF	20000 hours (20°C, predicted)
Lifetime (predicted)	15 years

- ◆ Rate range (measurement) - grade 4.0 (linearity error - 4%)
- ◆◆ Rate range (indication) - 300 deg/s (min) (linearity error - 15%)

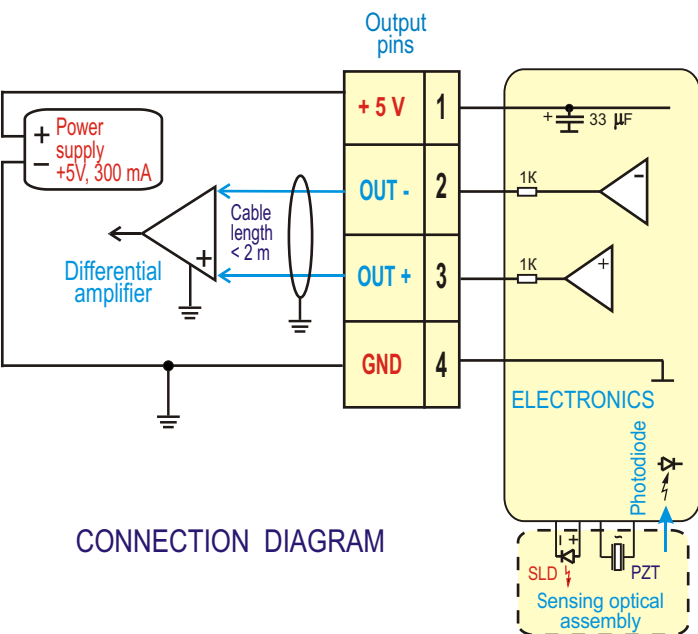

CONNECTION DIAGRAM

Output pins (PLS2-4S)

Contact	Name	Description
1	+ 5 V	Power input + 5V ± 0.25V, 200mA max, ripple 10mV max within 0-1MHz
2	OUT -	Analog output (~ - 3 mV/ °/s), 1V biased to "GND" *
3	OUT +	Analog output (~ + 3 mV/ °/s), 1V biased to "GND" *
4	GND	Power return line, ground.

* - sensor's output is a difference between the voltages at 3 and 2 contacts

MOUNTING AND CONNECTING

1. Ω - sensing axis, 90°± 1° to the reference plane
2. Dissipation - 1 W
3. Weight - 55 gram (80 gram max)
4. Volume - 0.07 litre
5. Housing material - plastic
6. Undisclosed tolerances - 0.5 IT14

1. Do not deform housing and output pins.
2. It is recommended to use 2 diagonal screws with elastic washers for mounting.
3. Fragile components inside - no shocks, no drop
4. Treat as electrostatic sensitive unit
5. Power must be off during connecting
6. Soldering to contacts by low-temperature solder