

OUTLINE DRAWING

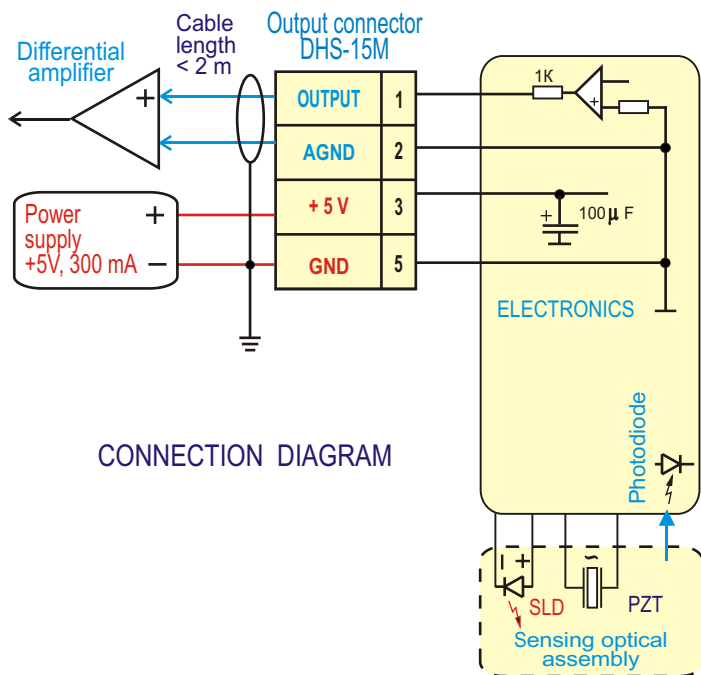

CONNECTION DIAGRAM

MAIN PARAMETERS

- ◆ Rate range 60 deg/s
- ◆ Scale Factor (SF) 24 mV/deg/s
- ◆ Frequency range 0... 0.45 kHz
- ◆ Angle random walk 0.015 deg /√h
- ◆ Bias stability 1 deg / h (RMS)
- ◆ SF variation (steady state) 0.1 % (RMS)
- ◆ Readiness time 0.1 s

ENVIRONMENT

- ◆ Temperature operating -30°C ... +70°C
- ◆ Temperature endurance -55°C... +85°C
- ◆ Vibration (operating) 2 g (RMS), 20Hz... 500Hz
- ◆ Vibration (endurance) 2 g (RMS), 20Hz... 500Hz
- ◆ Shocks (endurance) 40 g, 1 ms
- ◆ Acceleration (operating) 5 g
- ◆ Acceleration (endurance) 20 g, 5 s

RELIABILITY

- ◆ MTBF 20000 hours (20°C, predicted)
- ◆ Lifetime (predicted) 15 years

- ◆ Rate range (measurement) - grade 4.0 (linearity error - 4%)
- ◆ Rate range (indication) -80 deg/s (min) (linearity error - 15%)

Output connector DHS-15M

| Contact | Name | Description |
|---------|--------|--|
| 1 | OUTPUT | Output voltage proportional to rotation, scale factor - 24 mV/deg/sec. Differential input recommended. |
| 2 | AGND | Analog ground to use with "OUTPUT". Differential input recommended. Galvanic coupling with "GND". |
| 3 | + 5 V | Power input +5V ± 0.25V, 300mA max, ripple 10mV max within 0-1MHz |
| 5 | GND | Power return line, ground. |
| 4,6-15 | — | Not used |

1. Ω - sensing axis, 90° ± 0.5 ° to the reference plane
2. Dissipation - 1.5 W
3. Weight - 320 gram (400 gram max)
4. Volume - 0.55 litre
5. Housing material - plastic
6. Tolerances - ± 0.5 IT14

MOUNTING AND CONNECTING

1. Do not deform housing and output pins
2. Fragile components inside - no shocks, no drop
3. Treat as electrostatic sensitive unit
4. Power must be off during connecting